

**W**ith more than 27 years of experience in the development and manufacturing of heavy-duty CNC lathes and manual lathes, L&L is an international recognized lathe manufacturer with products sold to over 20 countries around the world.

L&L heavy-duty lathes are designed with just one thought in mind, to maximize metal cutting productivity. The combination of rugged structure, maximum stability and great cutting capacity, coupled with lifetime accuracy make L&L heavy-duty lathes excellent for any application. These applications range from and include, general parts machining, the mining industry, shafts, molds, power utilities and rollers, the oil industry and the aviation industry.

Every L&L machine is built to the highest quality standards. Each one has been subject to the most comprehensive tests and inspections according to CNC 7000, ISO 1708, and VDI 3441 standards prior to shipping, assuring our customers of the best possible machines that they've come to expect.

#### Professional Series Lathes

- *LA/A Series- Heavy Duty Manual Lathes*
- *TA Series- High Quality Standard CNC Lathes*
- *MA/MA-U Series- Double Turret CNC Lathes*
- *LC/LD Series- Precision CNC Lathes*
- *LS-S/LS-U/LS-C Series- Heavy Duty CNC Boring Lathes*
- *LFS/LFM Series- Large CNC Lathes*
- *LL Series- 5 Bed Way Heavy Duty CNC Lathes*
- *LLA Series- 4 Axis Turning Milling Center*
- *LLB Series- 4 Axis Milling Turning Center*
- *LLB-BC Series- 5 Axis Milling Turning Center*
- *LLB-AC Series- Intelligent 5-Axis Milling Turning Center*  
· Simultaneous Multi-process 5-Axis system

## 5 Bed Way CNC Turning Boring Lathe Processing Large Shaft Constantly



CNC LATHE | LL550 | LL750 | LL950

# L&L

L&L Machinery Industry Co., Ltd.

#### Taiwan Headquarters

No. 73, Industry 20th Rd. Taiping,  
Taichung, Taiwan

Tel: +886-4-2271-5727

Fax: +886-4-2271-6561

Website: [www.lmachinery.com.tw](http://www.lmachinery.com.tw)

E-mail: [service@llmachinery.com.tw](mailto:service@llmachinery.com.tw)

**intaima**  
machinery alliance

[www.intaima.com](http://www.intaima.com)

#### China Branch

KUNSHAN L&L  
MACHINERY INDUSTRY CO., LTD.

Tel: +86-512-5707-5518

Fax: +86-512-5707-5517

E-mail: [cnlandlmac@yeah.net](mailto:cnlandlmac@yeah.net)

[george@llmachinery.com.tw](mailto:george@llmachinery.com.tw)

**L&L**  
L&L Machinery Industry Co., Ltd.

**27**  
YEARS

## STRUCTURE

**Headstock**

- The solid box-construction casting provides excellent rigidity for heavy cutting.
- All gears and headstock are hardened and precisely ground.
- Double chucks would strengthen the stability for turning long workpiece by spindle.

**Chuck**

- Manual, hydraulic, pneumatic chucks are available.
- Have various chuck diameters for optional.

**Steady Rest**

- Manual steady rest.
- Fixed hydraulic steady rest.
- Programmable hydraulic steady rest.

**Boring Attachment**

- Have different sizes for selection.
- Included boring bar and boring bar tool holder.
- The boring depth and diameter can be controlled by program.

**Tailstock**

- Body movement: Motorized. (STD.)  
By carriage drives (manual/hydraulic) (OPT.)
- Quill movement: Motorized or manual (STD.)  
By hydraulic (OPT.)

**Cross slide**

- The box type designed for cross slide.
- The X-axis ball screw is installed in the center of two box type cross slide.

**Carriage**

- High-low box type bed ways for carriage.
- The Z-axis ball screw is installed in the center of high-low type bed ways.

Linear encoder  
(OPT.)

Support Unit  
For support the ball screw,  
driven by linear guide.



LL  
SERIES

# HEADSTOCK

Manual, Hydraulic, Pneumatic chucks are available

Hardened and ground spindle gears Modulus 5

Super rigid and precise spindle

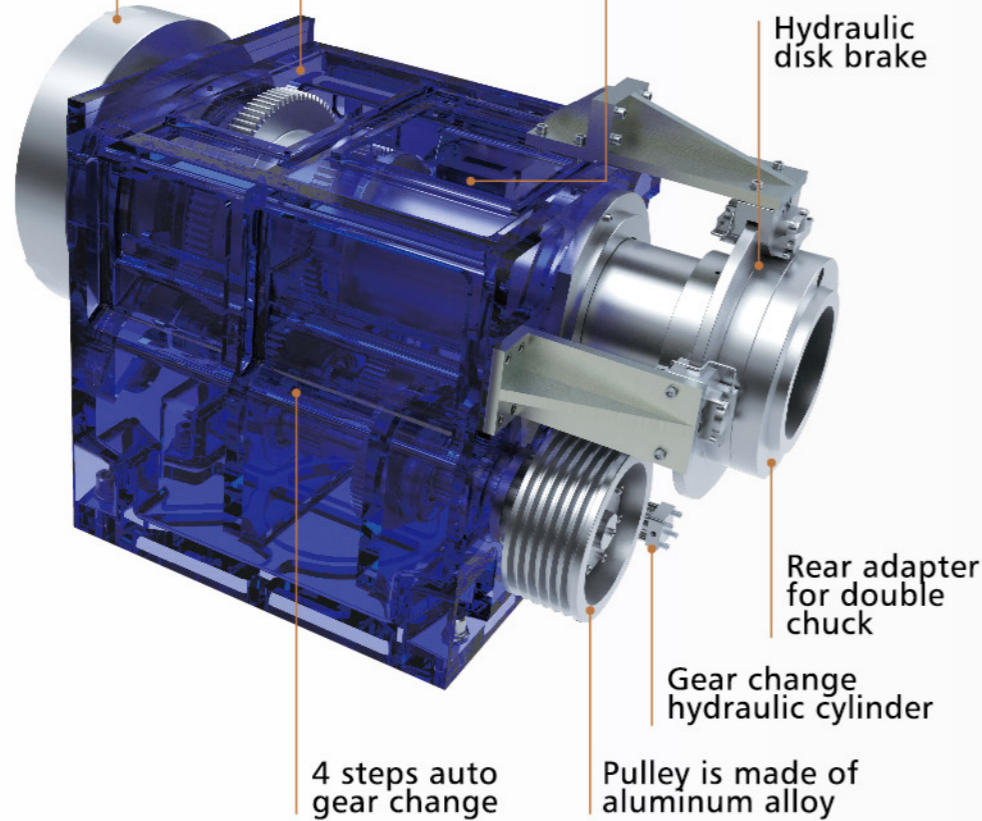

Hydraulic disk brake

Rear adapter for double chuck

Gear change hydraulic cylinder

4 steps auto gear change

Pulley is made of aluminum alloy

	LL550	LL750/LL950
Spindle Bore	Ø153mm(6") Ø230mm(9") Ø305mm(12") -	Ø153mm(6") Ø230mm(9") Ø305mm(12") Ø405mm(16")

## Headstock

- All gears in headstock are hardened and precisely ground.
- The spindle is supported by high precision taper roller bearings.
- Spindle speed ranges are automatically changed by M code.
- Variable speeds are commanded by S code.
- An auto-lubrication system is equipped for headstock gears and spindle.
- We use the best SCM-435-440 chromium molybdenum steel material for our spindles, to ensure the spindle accuracy and durability.

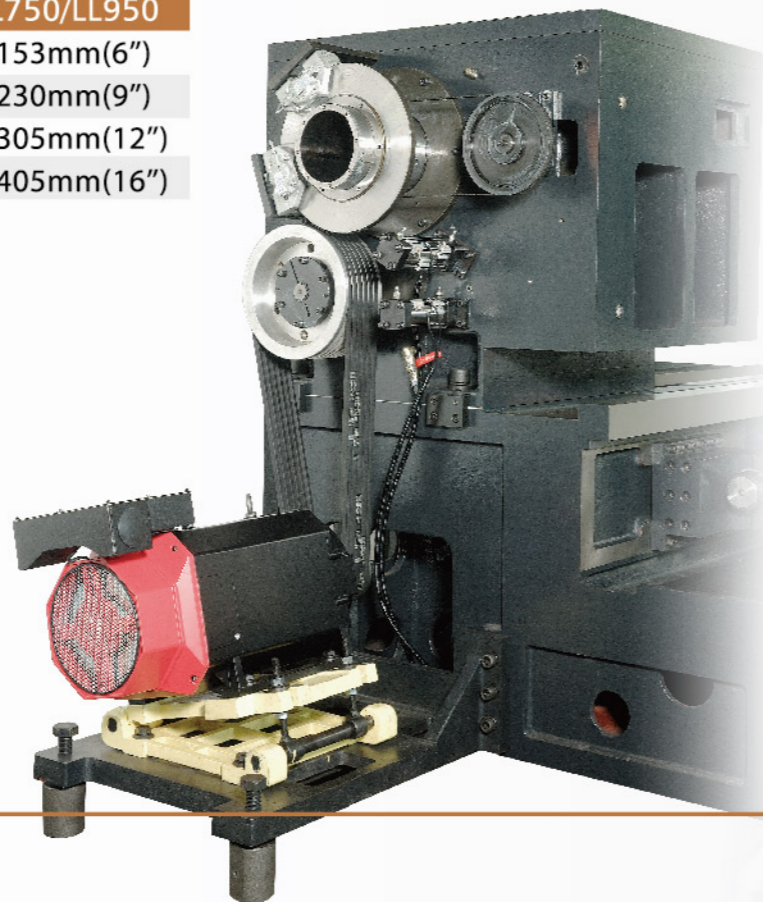

LL  
SERIES

# CHUCK

4 Jaw hydraulic hollow power chuck

3 Jaw hydraulic hollow power chuck

4 Jaw manual chuck

3 Jaw manual chuck



3 Jaw hydraulic solid power chuck

Specification	Size
3 Jaw manual chuck	20" / 25" / 32" / 40"
4 Jaw manual chuck	20" / 25" / 32" / 40"

Specification	Size
3 Jaw hydraulic solid power chuck	15" / 18" / 21" / 24" / 32" / 40"
3 Jaw hydraulic hollow power chuck	15" / 18" / 20" / 24"
4 Jaw hydraulic hollow power chuck	15" / 18" / 21" / 24" / 32" / 40"

## Chuck

- Manual, hydraulic, pneumatic chuck are available.
- Chucks are with excellent concentricity and rapid clamping.
- The second chuck can be mounted on spindle rear adapter.
- Jog button design can help chuck to clamp workpiece easily.

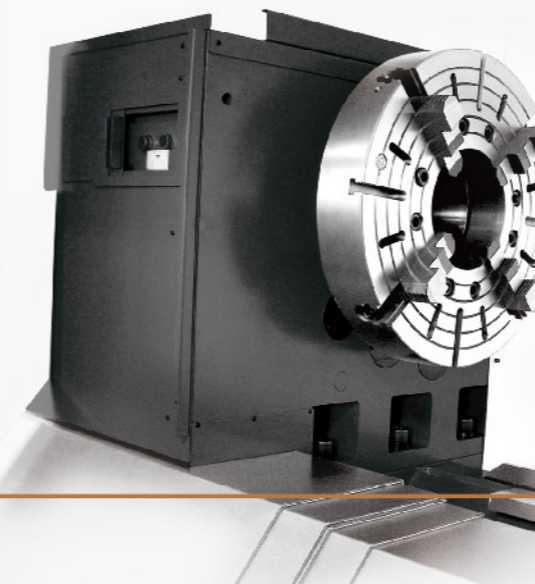

LL  
SERIES

## TURRET, STEADY REST, CARRIAGE

## Driven Power Tool Turret : BMT75

Specification	STD	OPT
Tool Size	32	25
Twist drill & Milling cutters	Ø3~Ø26 (ER40)	
Boring Bar Holder	Ø50	Ø40
Boring Bar Sleeve(mm)	Ø12, Ø16, Ø20, Ø25, Ø32, Ø40, Ø50	



## Hydraulic Turrets : V12-160 / V12-200

Model	LL550		LL750 / LL950	
	V12-160		V12-200	
Specification	Size(STD.)	Size(OPT.)	Size(STD.)	Size(OPT.)
Tool	32	40	32	40
Boring Bar Holder	Ø50	Ø60 Ø80 Ø100	Ø50	Ø60 Ø80 Ø100
Boring Bar Sleeve(mm)	Ø40 Ø32 Ø25 MT#4	-	Ø40 Ø32 Ø25 MT#4	-

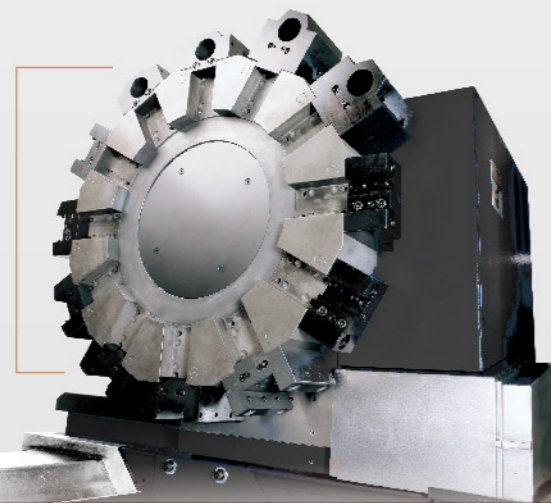
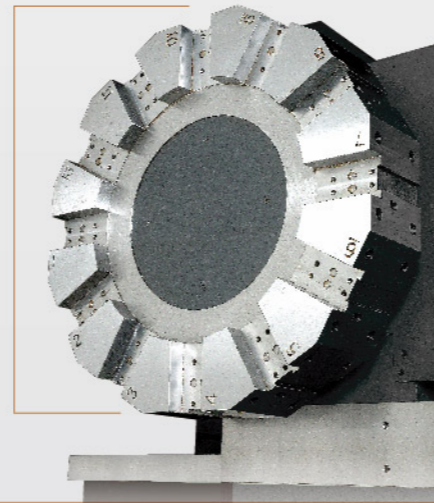
LL750 / LL950:  
V12-200  
turretDisk diameter:  
660 mmLL550:  
V12-160  
turretDisk diameter:  
580 mm

## Hydraulic Steady Rest ▶

- Clamping different diameter work piece auto adjustment.
- High concentricity.
- Motorized body movement.
- Clamping and unclamping controlled by M code.

Brand	SMW	SCHUNK
	Ø30~Ø245mm	Ø85~Ø350mm
Clamping Capacity	Ø85~Ø350mm	Ø125~Ø460mm
	Ø215~Ø510mm	-
	Ø300~Ø700mm	-



## ◀ Manual Steady Rest

- Ø80mm quill.
- Three point heavy duty needle roller bearing.
- Tool can pass steady rest without interference.
- Capacity : 100-300mm, 300-500mm, 500-750 mm.



Quill Dimension	Ø80mm
Clamping Capacity	Ø100~Ø300mm Ø300~Ø500mm Ø500~Ø750mm

## Boring Attachment and Sub Carriage (OPT.) ▶

- Included boring bar and boring bar tool holder.
- Boring attachment is available to be mounted on sub carriage.
- The boring depth and diameter can be controlled by program.
- Depending on client requirement, the boring bar sleeve can be addition.

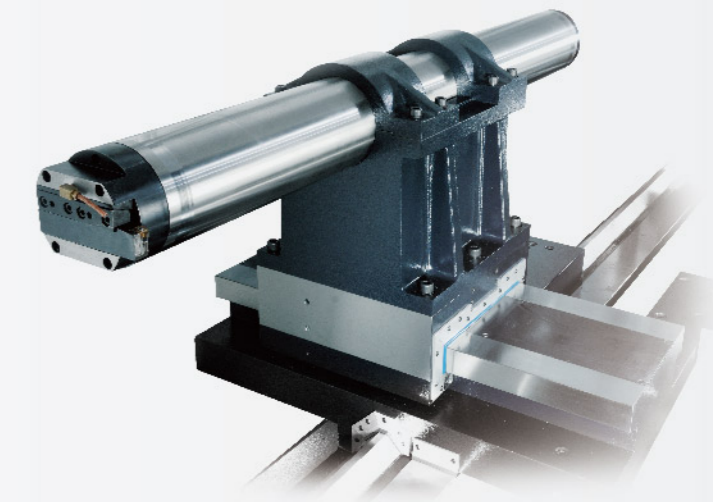

## Carriage ▼

- No interference between carriage and steady rest.
- "Box type" carriage and cross slide.
- Turcite B lining is applied on cross slide and carriage to reduce friction.
- Customer can select the manual or automatic to drive the main carriage combine with sub carriage and boring attachment.



LL  
SERIES

## TAILSTOCK

- High-precision rotary mandrel provides maximum rigidity and high load capacity.
- With 2 heavy duty taper roller bearings, 1 spherical roller thrust bearing and 1 angular ball bearing are installed.
- MT#6 stationary center or live centers are available.
- Electric and manual quill movement provides easy quill positioning.
- A powerful motor drives body movement.
- Quill and body movement have hydraulic or carriage drive for options.

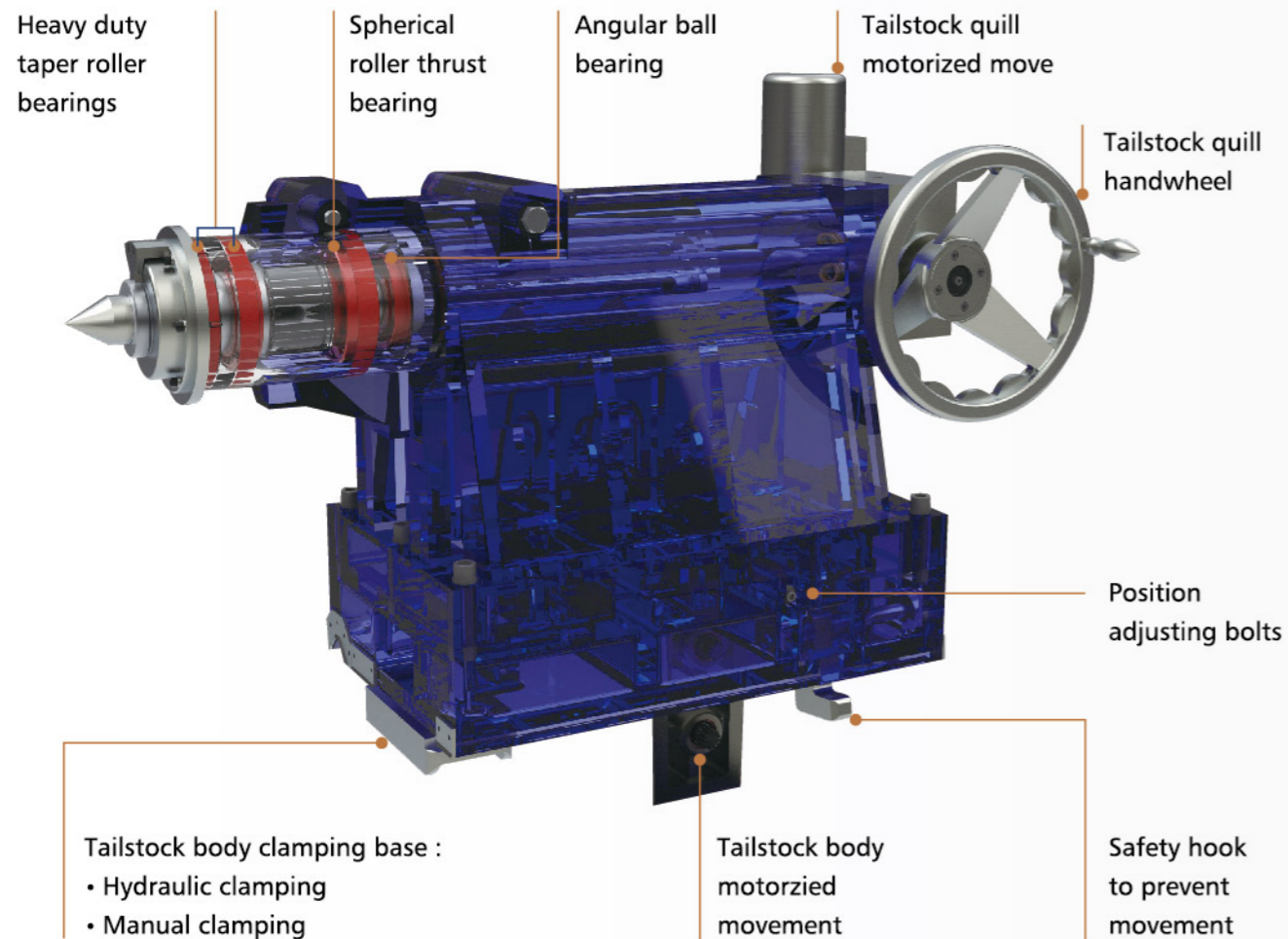
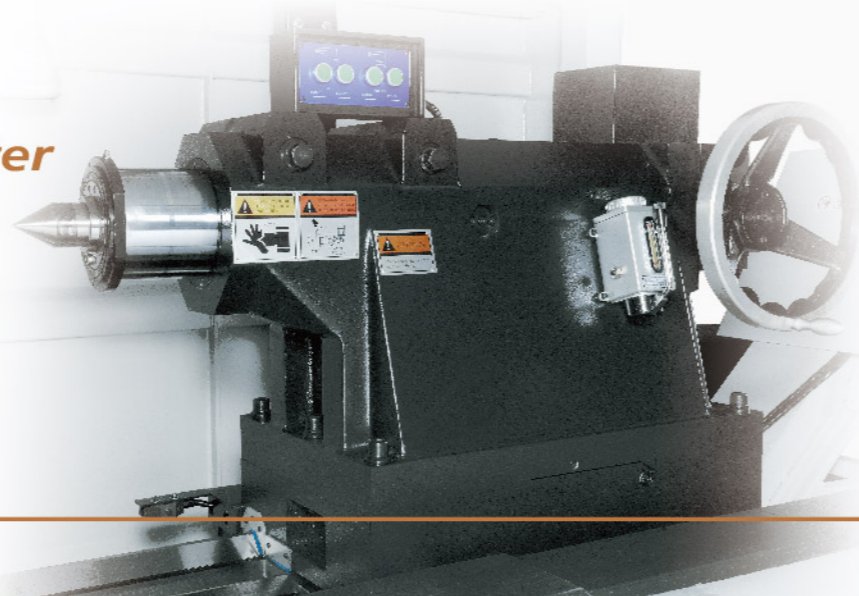
**Tailstock Quill Diameter**LL550 :  
**Ø165 / Ø200 mm**LL750 / LL950 :  
**Ø200 / Ø250 mm**LL  
SERIES

## TRANSMITTING SYSTEM AND EQUIPMENT

**High Pressure Cooling System**

- High pressure coolant pump option 15, 30, 70 Bar.

**Chip Removal**

- Rear chip conveyor + one cart  
Front spiral chip former/set chip flute + water tank
- Front and rear chip conveyor + two carts
- Two front chip conveyor and two rear chip conveyor + 4 carts

**Splash Guard Type**

- Front two doors + rear splash guard (STD.)
- Fully enclosed guard (OPT.)

## TRANSMITTING SYSTEM

**• No drifting of carriage**

Z-axis ball screw is installed in the center of two box type bed ways.

**• No vibration**

- 3-5 m: Ball screw rotating (including 1:4 planetary gear reducer)
- 6-10 m: Nut rotating (including precise helical gear)
- Over 10 m: Pinion and rack (including REDEX 1 : 31 plenty gear reducer)

**• High accuracy**

This system prevents vibration of long ball screw, increasing position accuracy and reducing noise.

**• No chip damage**

Z-axis ball screw is protected by fully enclosed telescopic cover.

**• Durable**

Ball screw is supported by linear slide. To make sure of the linearity, there is no bending or vibration of long ball screw.

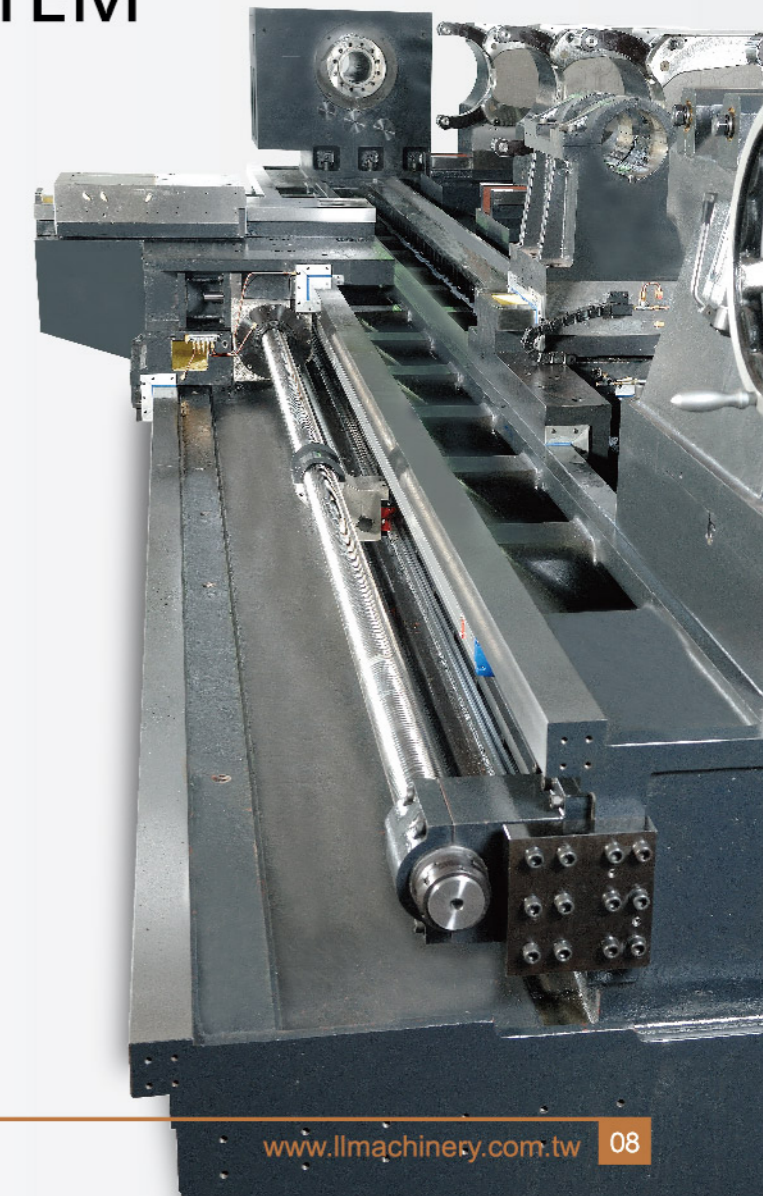



# CNC CONTROLLER

## FANUC 0i-TF (STD.) FANUC 31i-B (OPT.)

User-friendly control panel allows direct operator access to most of the machine's setup functions, without the hassle of flipping through pages in the control screen.

Standard 10.4" color LCD screen, small full keypad, graphic display, 640M of program memory and superfast processor.

Standard Manual Guide i conversational programming simplified program, and advanced canned cycles for complex machining can be carried out automatically.



## SIEMENS 828D (OPT.) SIEMENS 840D (OPT.)

- Panel-based compact CNC
- Technologies: Turning, milling, grinding functions
- Up to 10 axes/spindles + 2 auxiliary axes
- Up to 2 machining channels
- 10.4" color display / 15.6" touch display
- S7-200 PLC based

Operator panel front made of magnesium die cast, the panel-based CNC design with well-conceived interfaces, as well as the high degree of protection IP 65.

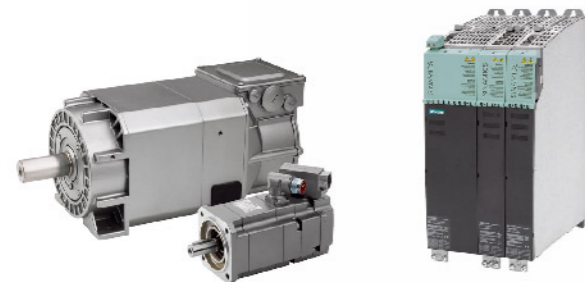

## FAGOR 8060 (OPT.)

Have proprietary features necessary for high speed machining while maintaining the best surface finish and accuracy.

The keyboards have been designed horizontal and vertical designs and in cooperation with machine operators to make navigation and data entry easier.

The control offers a 10.4" high resolution LCD TFT Color or touch screen, Ethernet, USB and Tele-Diagnosis capability that can control up to 6 axes and 3 separate spindles, with 2 different execution channels.



## Spindle Motor Power Curves & Torque Chart Fanuc Spindle Motor

**Model Fanuc αiI 22/7000 (22/26kW STD.)**

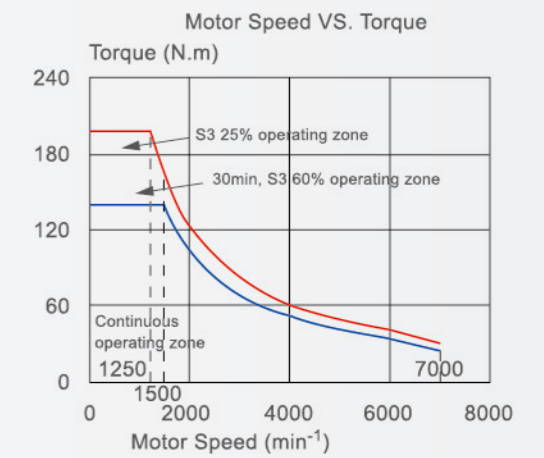
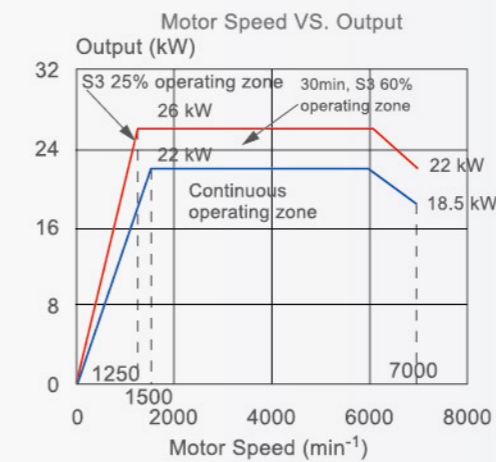

**Model Fanuc αiI 40/6000 (37/45 kW OPT.)**

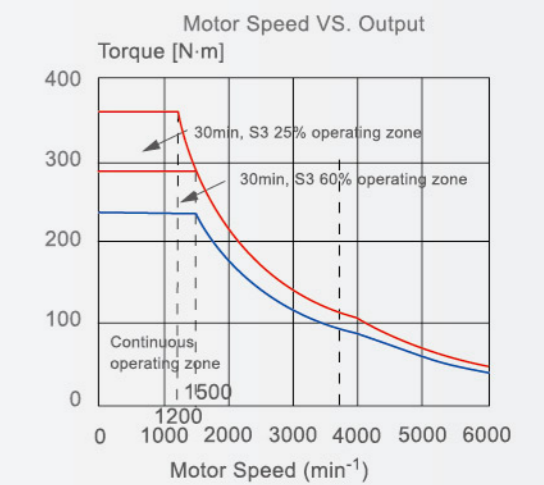
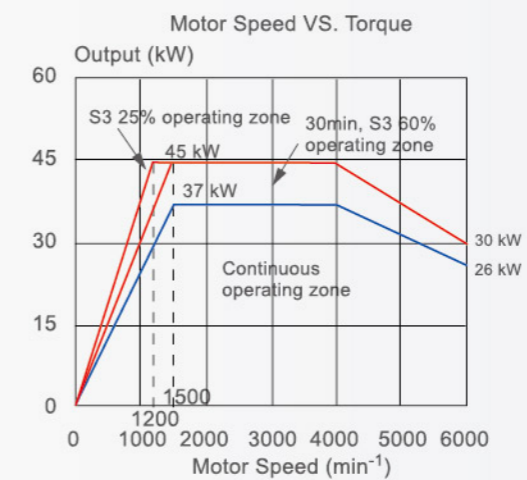

## Loading Capacity

MODEL	LL550 / LL750				LL950			
SPINDLE BORE	6" A2-11	9" A2-15	12" A2-20	16" A2-28	6" A2-11	9" A2-15	12" A2-20	16" A2-28
TAILSTOCK QUILL DIAMETER	165 mm	165 mm	165 mm	165 mm	200 mm	200mm	200 mm	200 mm
1 Max. load between centers	6000 kgs	7000 kgs	8000 kgs	9000 kgs	7000 kgs	8000 kgs	9000 kgs	10000 kgs
2 Max. load between centers plus 1 steady rest	7000 kgs	8000 kgs	9000 kgs	10000 kgs	8000 kgs	9000 kgs	10000 kgs	11000 kgs
3 Max. load between centers plus 2 steady rest	8888 kgs	9000 kgs	10000 kgs	11000 kgs	9000 kgs	10000 kgs	11000 kgs	12000 kgs
4 Max. load with one chuck only	2000 kgs	2200 kgs	2400 kgs	2600 kgs	2200 kgs	2400 kgs	2600 kgs	2800 kgs

## LL 550 SERIES

## LL 750 SERIES

## LL 950 SERIES

## Interference Drawings

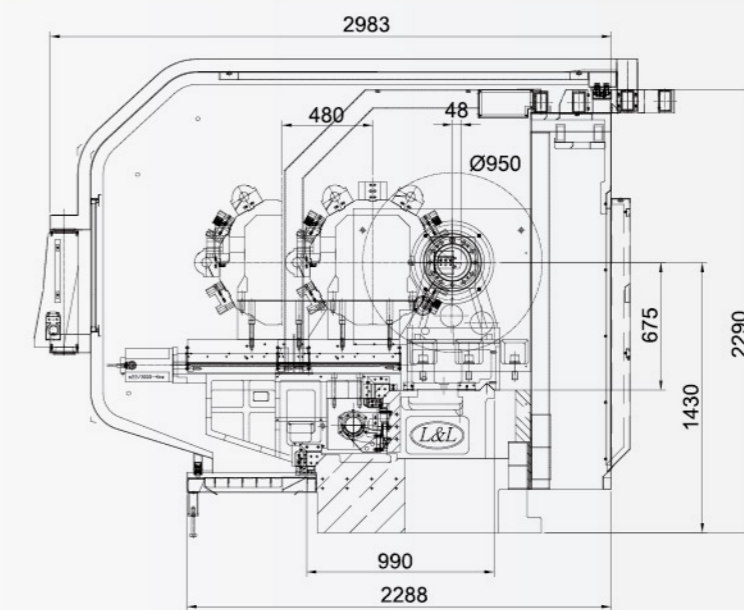
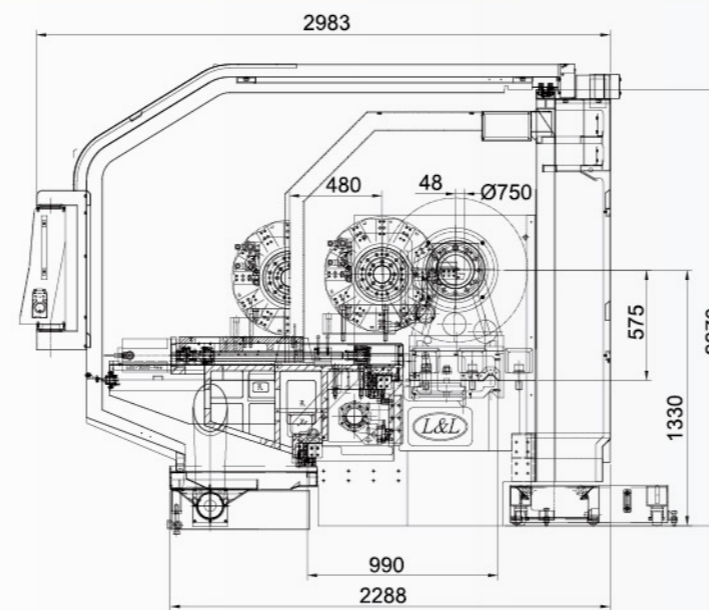
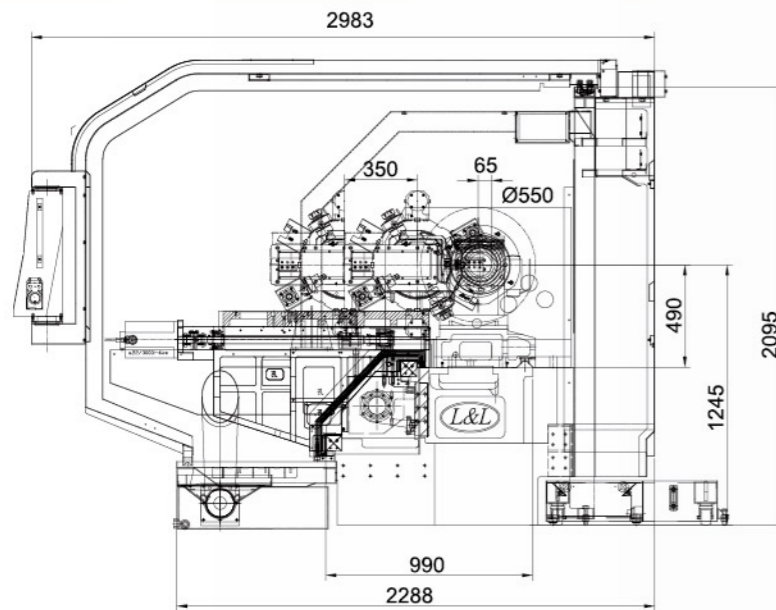

## Dimensional Drawings

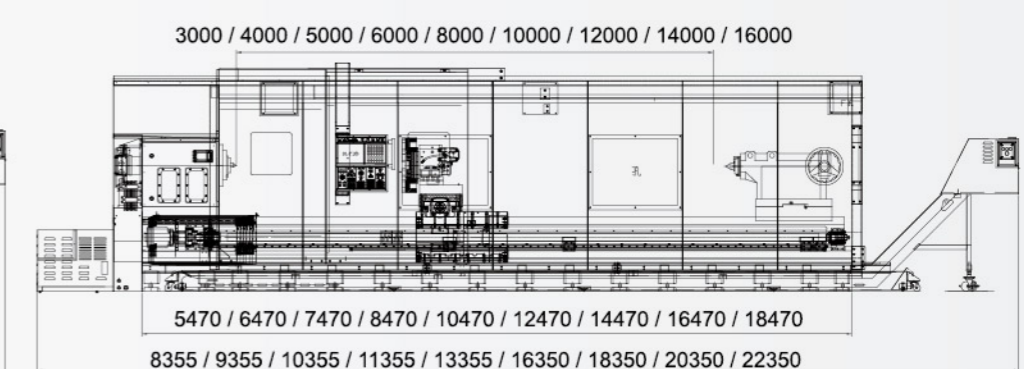
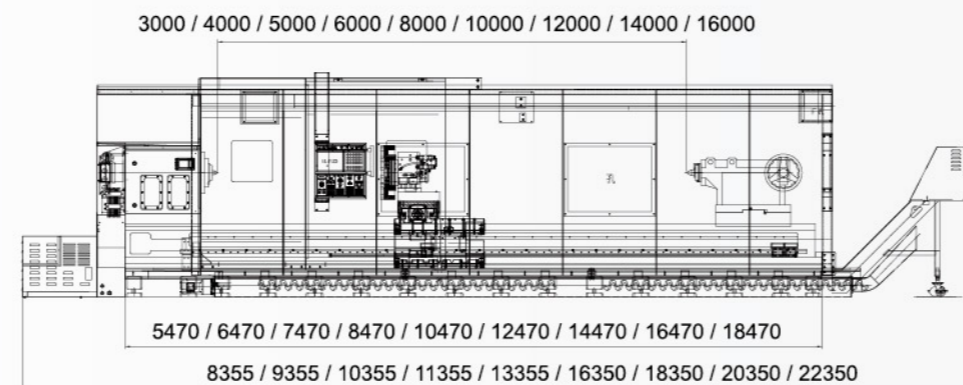
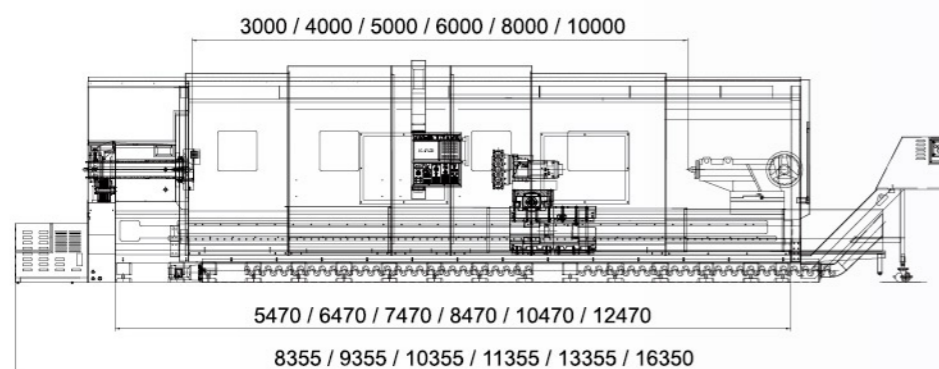

## Machine Dimensions and Weight

LL550 series	BC 3000 mm	BC 4000 mm	BC 5000 mm	BC 6000 mm	BC 8000 mm	BC10000 mm
L x W x H (mm)	5470 x 3050 x 2370	6470 x 3050 x 2370	7470 x 3050 x 2370	8470 x 3050 x 2370	10470 x 3050 x 2370	12470 x 3050 x 2370
N.W / G.W	11,700 / 12,700 kg	14,370 / 15,070 kg	17,040 / 17,370 kg	20,500 / 22,100 kg	25,660 / 24,850 kg	30,820 / 27,600 kg

LL750 series	BC 3000 mm	BC 4000 mm	BC 5000 mm	BC 6000 mm	BC 8000 mm	BC10000 mm	BC12000 mm	BC14000 mm	BC16000 mm
L x W x H (mm)	5470 x 3250 x 2370	6470 x 3250 x 2370	7470 x 3250 x 2370	8470 x 3250 x 2370	10470 x 3250 x 2370	12470 x 3250 x 2370	14470 x 3250 x 2370	16470 x 3250 x 2370	18470 x 3250 x 2370
N.W / G.W	12,700 / 13,700 kg	15,370 / 16,070 kg	18,040 / 18,370 kg	21,500 / 23,100 kg	26,660 / 25,850 kg	31,820 / 28,600 kg	36,980 / 31,350 kg	42,140 / 34,100 kg	47,300 / 36,850 kg

LL950 series	BC 3000 mm	BC 4000 mm	BC 5000 mm	BC 6000 mm	BC 8000 mm	BC 10000 mm	BC 12000 mm	BC 14000 mm	BC 16000 mm
L x W x H (mm)	5470 x 3450 x 2370	6470 x 3450 x 2370	7470 x 3450 x 2370	8470 x 3250 x 2370	10470 x 3450 x 2370	12470 x 3450 x 2370	14470 x 3450 x 2370	16470 x 3250 x 2370	18470 x 3450 x 2370
N.W / G.W	13,700 / 14,700 kg	16,370 / 17,070 kg	19,040 / 19,370 kg	22,250 / 24,100 kg	27,660 / 29,160 kg	32,950 / 34,100 kg	38,240 / 39,404 kg	43,530 / 43,980 kg	48,820 / 48,920 kg

Full line of high quality CNC lathes to meet your turning challenges.

# SPECIFICATIONS

Model	LL550	LL750	LL950	
Swing over bed	950 mm	1150 mm	1250 mm	
Maximum cutting diameter	Ø550 mm	Ø750 mm	Ø950 mm	
Center height	490 mm	575 mm	675 mm	
Distance between centers	3000/4000/5000/6000/ 8000/10000 mm	3000/4000/5000/6000/8000/ 10000/12000/14000/16000 mm		
Carriage type		Box type		
Carriage width		955 mm		
Cross slide width		450 mm		
Bed width		990 mm (39")		
Machine length	8355/9355/10355/ 11355/13355/16350 mm	8355/9355/10355/11355/13355/ 16350/18350/20350/22350 mm		
Bed way	Carriage Tailstock	2 box ways for carriage 1 V way and 2 flat ways for tailstock		
Controller	STD.	FANUC 0i-TF		
	OPT.	FANUC 31i-MODEL B / FAGOR 8060-T / SIEMENS 828D / SIEMENS 840D		
Spindle motor	STD.	FANUC	STD. 22/26kW 140Nm OPT. 30/37kW 249Nm OPT. 37/45kW 235Nm	
		OPT.	FAGOR	22/33kW 140Nm
			SIEMENS	22/29.5kW 140Nm
<b>Headstock</b>				
Spindle bore & Spindle nose	Ø153mm(6") A2-11 Ø230mm(9") A2-15 Ø305mm(12") A2-20	Ø153mm(6") A2-11 Ø230mm(9") A2-15 Ø305mm(12") A2-20 Ø405mm(16") A2-28		
Spindle speed	9~600 rpm / 9~500 rpm / 7~400 rpm / 5~250 rpm			
Spindle center	MT#6			
<b>Turret</b>				
Turret mode	STD.	V12-160	V12-200	
	OPT.	ODT-N32 (VDI60) DM-TR25 (BMT75)	ODT-N32 (VDI60) SMH-TR32 (BMT85)	
Tool size	32 mm / 1.25 inch			
<b>Tailstock</b>				
Quill diameter	1~6 m	Ø165 mm	Ø200 mm	
	Over 6 m	Ø200 mm	Ø250 mm	
Quill stroke	250 mm			
Tailstock center	MT#6			
Body movement	STD.	Motorized (Induction motor + gear reducer) + rack and pinion		
	OPT.	By carriage (manual/hydraulic) Motorized (Servo motor+ gear reducer) + rack and pinion		
Quill movement	STD.	Motorized / by manual		
	OPT.	By hydraulic		
<b>Feed</b>				
X-axis rapid traverse	5000 mm/min			
X-axis ballscrew	Ø40 mm*P5			
X-axis feed range	0.1~3000 mm/min			
X-axis stroke	370 mm	480 mm		

Model	LL550	LL750	LL950
X-axis servo motor and transmitting	STD.	FANUC	STD. 3 kW 12 Nm OPT. 4 kW 22 Nm
		FAGOR	5.2 kW 16.5 Nm
	OPT.	SIEMENS	3.3 kW 16 Nm
Z-axis rapid traverse	5000 mm/min		
Z-axis ballscrew	Ø80 mm*P10		
Z-axis feed range	0.1~3000 mm/min		
Z-axis stroke	3000/4000/5000/6000/8000/10000/12000/14000/16000 mm		
Z-axis servo motor and transmitting	Between centers 3~5 m		
	Ball screw rotates + 1 : 4 planetary gear reducer		
	STD.	FANUC	STD. 4 kW 22 Nm OPT. 7 kW 30 Nm
		FAGOR	3.8 kW 23.5 Nm
	OPT.	SIEMENS	4.87 kW 27 Nm
	Between centers 6~10 m		
	Nut rotates + helical gear reducer		
	STD.	FANUC	7 kW 30 Nm
	OPT.	FAGOR	6.3 kW 32 Nm
		SIEMENS	5.37 kW 36Nm
	Between centers over 10 m		
Pinion and rack + REDEX 1 : 31 plenty gear reducer			
STD.	FANUC	7 kW 30 Nm	
OPT.	FAGOR	6.3 kW 32 Nm	
	SIEMENS	5.37 kW 36 Nm	

## Standard Accessories

Lubrication pump	Spindle	1/4 HP 6.5 L/min
	Carriage	30 W 130 c.c./min
Coolant pump	STD.	15 Bar
	OPT.	30 Bar / 70 Bar
Hydraulic pump	2 HP	
Chip movement	Rear chip conveyor + one cart	
	Front spiral chip former/ set chip flute + water tank	Front and rear chip conveyor + two carts
Between centers over 10m :Two front chip conveyor and two rear chip conveyor + 4 carts		
Guard	STD.	Front two doors + rear splash guard
	OPT.	Fully enclosed guard
Machine color	Machine body black(RAL9011)+ splash guard and doors white(RAL7047)	
<b>Steady Rest</b>		
Steady rest quill diameter	Ø80 mm	Ø105 mm
Steady rest capacity	Ø100~Ø300, Ø300~Ø500, Ø500~Ø750 mm	Ø750~Ø950 mm
Hydraulic steady rest	Ø30~Ø245, Ø85~Ø350, Ø215~Ø510 mm	
Programmable steady rest	It can be retracted to avoid interference with the workpiece when the steady is not be in used.	
<b>Optional Accessories</b>		
X/Z-axis linear encoder		
C-axis system and angle encoder		

- Note :
1. X-axis and Z-axis actual cutting traverse will change when equipped with different turrets.
  2. Spindle speed will change according to different motors.
  3. Machine length includes the length of chip conveyor.
  4. Distance between centers will change based on installing different types of tailstocks.
  5. Specification subject to change without prior notice.